

# MACTECH

# BB2250 TAPERED BORING ATTACHMENT

MACTECHONSITE.COM

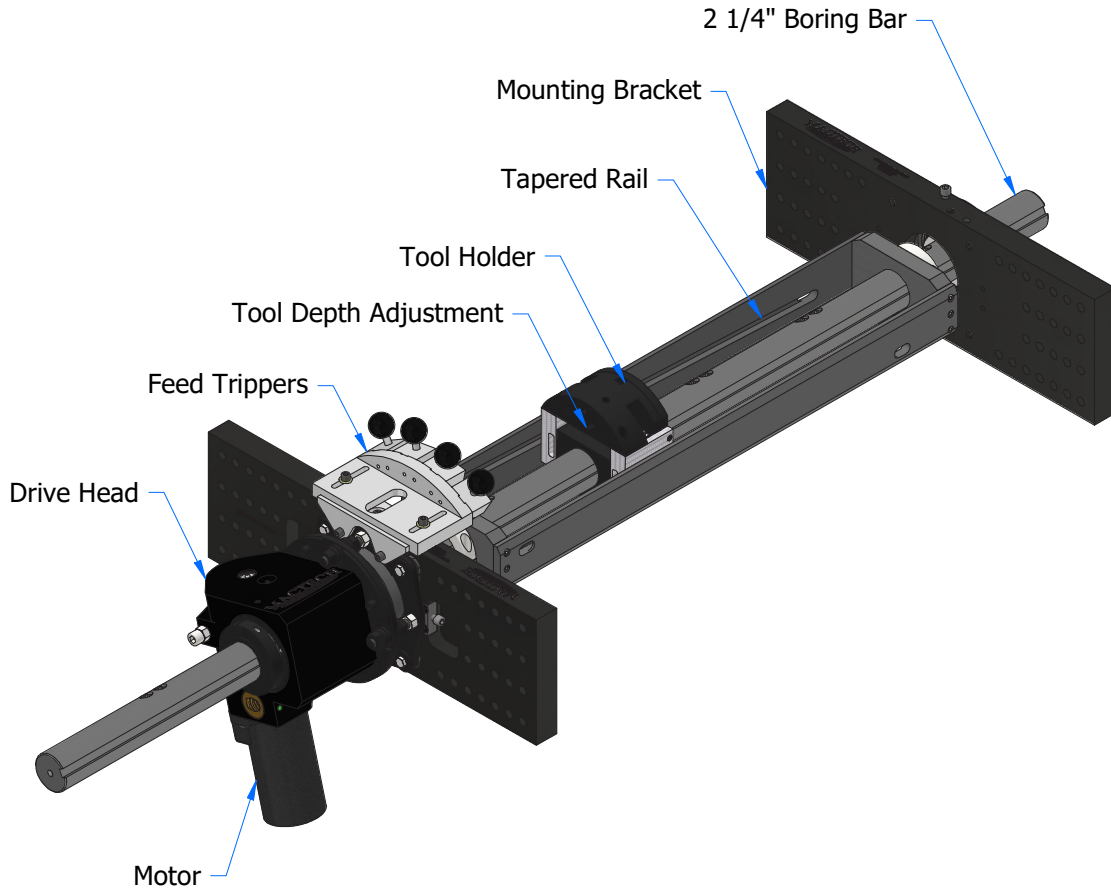

## FEATURES

- WORKS WITH STANDARD BB2250 DRIVE HEAD
- TAPER IS CUSTOMIZABLE, CAN BE SPECIFIED IN DEGREES OR DISTANCE PER FOOT
- MULTIPLE FEED TRIPPERS FOR VARIABLE FEED RATES
- ACCEPTS HALF INCH TOOLING
- HYDRAULIC, ELECTRIC, AND AIR DRIVE MOTOR OPTIONS

## SPECIFICATIONS

Travel	Up to 28" (711mm)
Minimum Bore	7.5" (191mm)
Maximum Bore	16.2" (410mm)
Feed Rates	.003, .007, .010, .013

Dimensions on Next Page

**MACTECH INC.**  
4079 PEPIN AVE UNIT 4  
RED WING MN 55066  
800-328-1488  
INFO@MACTECHONSITE.COM

**MACTECH OFFSHORE**  
302 IDA ROAD  
BROUSSARD LA 70518  
337-839-2793  
INFO@MACTECHOFFSHORE.COM

**MACTECH KENTUCKY**  
3880 INDUSTRIAL DRIVE  
PADUCAH KY 42001  
270-442-1559  
INFO@MACTECHONSITE.COM

**MACTECH WISCONSIN**  
2515 CLEVELAND AVE  
MARINETTE WI 54143  
800-328-1488  
INFO@MACTECHONSITE.COM

**MACTECH INTERNATIONAL**  
CONTACT US FROM ANYWHERE  
AROUND THE WORLD  
337-839-2793  
INFO@MACTECHOFFSHORE.COM

WORK HARD

WORK SAFE

WE BEFORE ME

WELCOME CHALLENGES

WOW THEM

# MACTECH

# BB2250 TAPERED BORING ATTACHMENT

MACTECHONSITE.COM

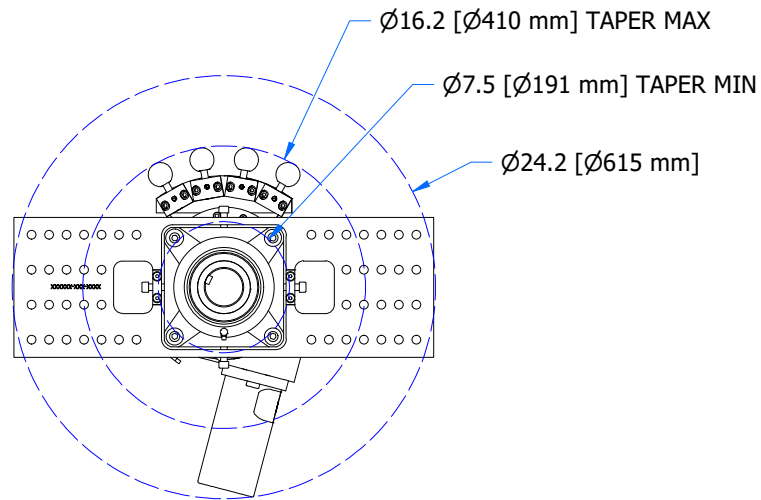
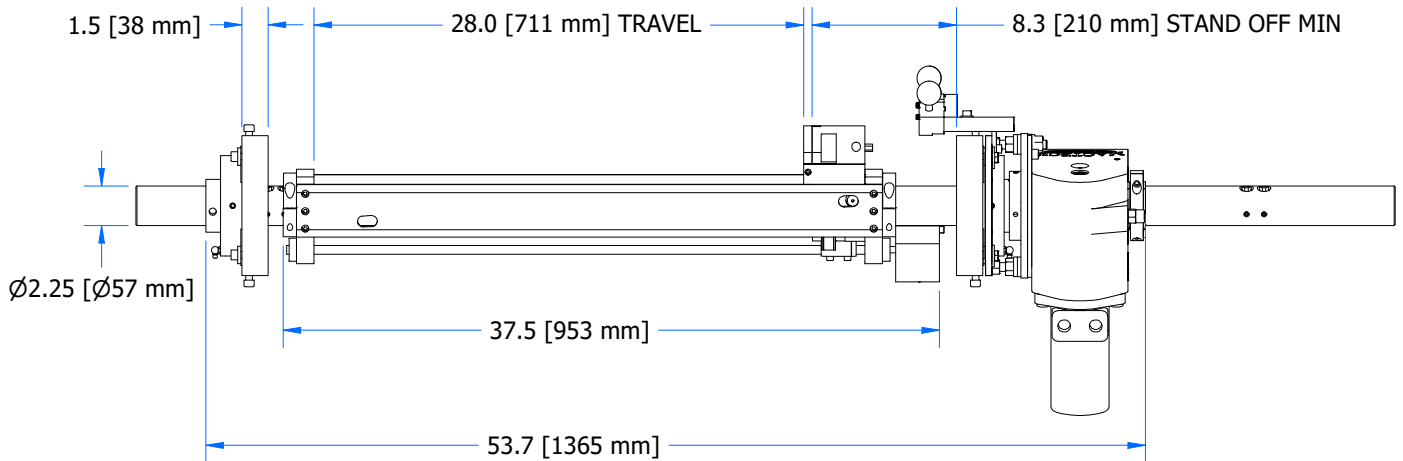

All dimensions and requirements are for reference and may be subject to change without notice. Machine performance is subject to application and operator capability; please discuss your requirements directly with a Mactech sales representative. All information given and all sales made by Mactech Inc. are subject to their terms and conditions.

**MACTECH INC.**  
4079 PEPIN AVE UNIT 4  
RED WING MN 55066  
800-328-1488  
INFO@MACTECHONSITE.COM

**MACTECH OFFSHORE**  
302 IDA ROAD  
BROSSARD LA 70518  
337-839-2793  
INFO@MACTECHOFFSHORE.COM

**MACTECH KENTUCKY**  
3880 INDUSTRIAL DRIVE  
PADUCAH KY 42001  
270-442-1559  
INFO@MACTECHONSITE.COM

**MACTECH WISCONSIN**  
2515 CLEVELAND AVE  
MARINETTE WI 54143  
800-328-1488  
INFO@MACTECHONSITE.COM

**MACTECH INTERNATIONAL**  
CONTACT US FROM ANYWHERE  
AROUND THE WORLD  
337-839-2793  
INFO@MACTECHOFFSHORE.COM

WORK HARD

WORK SAFE

WE BEFORE ME

WELCOME CHALLENGES

WOW THEM