

# MACTECH

## MT4 LRA BORING MILL 4" LINEAR RAIL BORING MILL

[MACTECHONSITE.COM](http://MACTECHONSITE.COM)

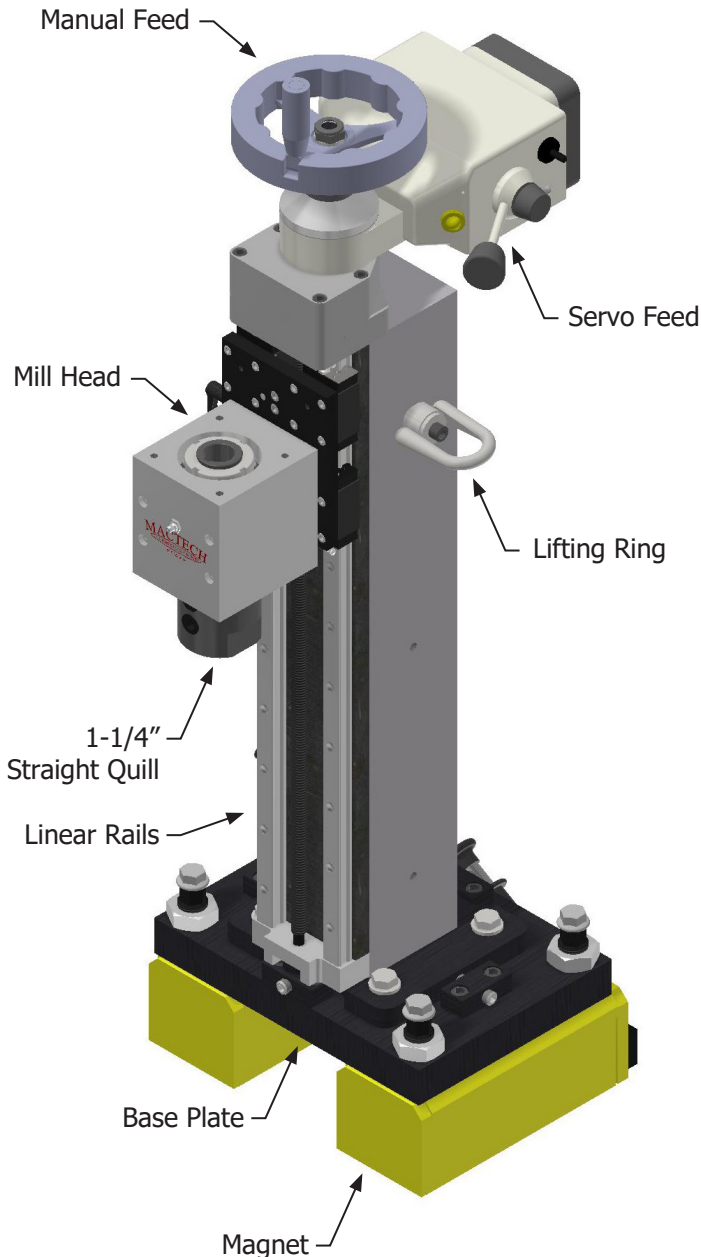

### PRODUCT DESCRIPTION

Mactech's MT4 LRA Boring Mill is a compact mill for stud removal, boring and other common drilling applications. The rigid design and easy setup makes your drilling operations fast and efficient. The MT4 LRA Boring Mill can be welded, clamped, bolted or magnetically attached directly onto the work piece in any orientation. The MT4 LRA Boring Mill is available for sale or rental.

### FEATURES

- **LINEAR RAILS, PRECISION FEED SCREWS AND RIGID CONSTRUCTION ENSURE ACCURATE MACHINING**
- **SMALL FOOTPRINT FOR RESTRICTED SPACES**
- **VARIETY OF MOUNTING OPTIONS**
- **VERSATILE AND PORTABLE**
- **HYDRAULIC, ELECTRIC OR AIR DRIVE**
- **WIDE RANGE OF TOOL HOLDERS AND CUTTERS AVAILABLE**

**MACTECH INC.**  
4079 PEPIN AVE UNIT 4  
RED WING MN 55066  
800-328-1488  
[INFO@MACTECHONSITE.COM](mailto:INFO@MACTECHONSITE.COM)

**MACTECH OFFSHORE**  
302 IDA ROAD  
BROSSARD LA 70518  
337-839-2793  
[INFO@MACTECHOFFSHORE.COM](mailto:INFO@MACTECHOFFSHORE.COM)

**MACTECH KENTUCKY**  
3880 INDUSTRIAL DRIVE  
PADUCAH KY 42001  
270-442-1559  
[INFO@MACTECHONSITE.COM](mailto:INFO@MACTECHONSITE.COM)

**MACTECH WISCONSIN**  
2515 CLEVELAND AVE  
MARINETTE WI 54143  
800-328-1488  
[INFO@MACTECHONSITE.COM](mailto:INFO@MACTECHONSITE.COM)

**MACTECH INTERNATIONAL**  
CONTACT US FROM ANYWHERE  
AROUND THE WORLD  
337-839-2793  
[INFO@MACTECHOFFSHORE.COM](mailto:INFO@MACTECHOFFSHORE.COM)

WORK HARD

WORK SAFE

WE BEFORE ME

WELCOME CHALLENGES

WOW THEM

# MACTECH

## MT4 LRA BORING MILL 4" LINEAR RAIL BORING MILL

MACTECHONSITE.COM

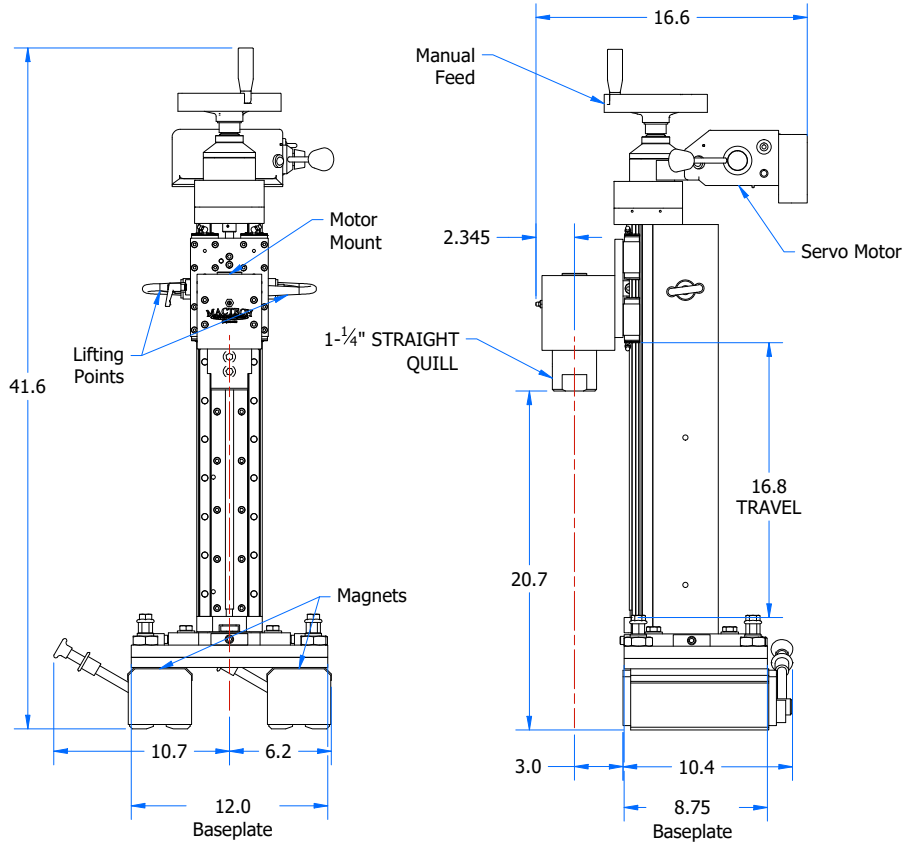

MODEL	TRAVEL	MAGNET BASE SIZE	BASE PLATE SIZE	HEIGHT	PACKAGE NUMBER
MT4 LRA x 24	16.8" (420mm)	12.4" x 10.4" (315 x 264mm)	12" x 8.75" (305 x 222mm)	41.6" (1057mm)	605-6944

### SPECIFICATIONS

The MT4 LRA x 24 Boring Mill is capable of boring up to 6-1/2 inch diameter holes through most materials.

**Tool Holder:** 1-1/4" Straight Quill.

Other tool holders and adapters are available.

**X-axis Feed:** 20" (508mm) per minute, electric servo feed

### DRIVES

Air (with filter/oiler caddy), hydraulic (with 36" hoses), or electric drives (110v, 220v, Reversible) are available.

Call Mactech to help you select the appropriate drive system for your application.

**MACTECH INC.**  
4079 PEPIN AVE UNIT 4  
RED WING MN 55066  
800-328-1488  
INFO@MACTECHONSITE.COM

**MACTECH OFFSHORE**  
302 IDA ROAD  
BROUSSARD LA 70518  
337-839-2793  
INFO@MACTECHOFFSHORE.COM

**MACTECH KENTUCKY**  
3880 INDUSTRIAL DRIVE  
PADUCAH KY 42001  
270-442-1559  
INFO@MACTECHONSITE.COM

**MACTECH WISCONSIN**  
2515 CLEVELAND AVE  
MARINETTE WI 54143  
800-328-1488  
INFO@MACTECHONSITE.COM

**MACTECH INTERNATIONAL**  
CONTACT US FROM ANYWHERE  
AROUND THE WORLD  
337-839-2793  
INFO@MACTECHOFFSHORE.COM

WORK HARD

WORK SAFE

WE BEFORE ME

WELCOME CHALLENGES

WOW THEM